

Non-invasive Ventilator

User Manual

Table of Contents

1. Introduction	4
2. Symbols	4
2.1 Symbols on the Labelling or Packaging	4
2.2 Symbols on the Product	5
2.3 Symbols on the User Interface	6
2.4 Symbols on the Manual	7
3. Warnings, Cautions and Important Tips	7
4. Intended Use	11
5. Contraindications	11
6. Specifications	13
7. Glossary	16
8. Product Introduction	18
8.1 Model and available therapies	18
8.2 Components	20
8.3 Overview	20
8.4 Package Contents	21
8.5 Working Principle	22
9. First Time Setup	22
9.1 Placing the Device	22
9.2 Installing and Replacing the Air Filter	23
9.3 Using the Humidifier	24
9.4 Assembling the tube and Mask	27
9.5 Connecting to Power	28
9.6 Operation Guide	28
10. Routine Use	29
10.1 Power on/off	29
10.2 Adjusting the tube	29







10.3	Turning on the Airflow	29
10.4	Humidify the air	30
10.5	Using the Ramp Feature	30
10.6	Viewing the report	31
10.7	Professional Setting	31
10.8	Navigating the Menu	32
10.9	Device Messages	37
10.10	Pairing with Pulse Oximeter	38
10.11	Pairing with ECG Recorder	39
11.	Using Wi-Fi, Bluetooth and Type-C	40
11.1	Connecting to Wi-Fi Network	40
11.2	Using the Bluetooth	40
11.3	Using Type-C	40
11.4	Cybersecurity	41
12.	Cleaning	42
12.1	Cleaning the Device	43
12.2	Cleaning the Mask and Tube	43
12.3	Cleaning the Water Chamber	43
13.	Maintenance	44
14.	Storage and Disposal	44
14.1	Storage	44
14.2	Disposal	44
15.	Troubleshooting	45
15.1	Common problems in patients and corresponding solutions	45
15.2	Common problems in the device and corresponding solutions	46
16.	Travelling with the Device	48
17.	EMC Requirements	48
18.	Limited Warranty	52





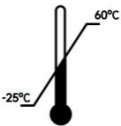
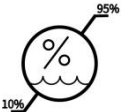







1. Introduction

Thank you for your purchase of the Non-invasive Ventilator of Viatom. This User Manual will introduce you to your device. Please read it carefully to ensure safe operation. If you experience any difficulties or problems during use, please contact your healthcare provider or physician.





2. Symbols





2.1 Symbols on the Labelling or Packaging

Symbol	Description
	Indicates the medical device can be broken or damaged if not handled carefully
	Indicates the medical device needs to be protected from moisture
	Indicates the temperature limits to which the medical device can be safely exposed
	Indicates the range of humidity to which the medical device can be safely exposed
	Follow Instructions for Use.
	Type BF Applied Part
	Class II (Double Insulated)
	Indicates that caution is necessary when operating the device or control close to where the symbol is placed, or that the current situation needs operator awareness or operator action in order to avoid undesirable consequences













Symbol	Description
	Non-Ionizing Radiation
	Indicates the item is a medical device
	Presents hazards in all MR environments such as strongly ferromagnetic materials
	Indicates separate collection for electrical and electronic device (WEEE).
IP22	≥ 12.5 mm Diameter, Dripping (15°tilted)
	Indicates the medical device manufacturer
	Indicates the date when the medical device was manufactured
	Indicates the manufacturer's serial number so that a specific medical device can be identified
	Indicates a carrier that contains unique device identifier information
	Batch code
	Indicated that the product complies with the EU Medical Device Regulations(Regulation (EU) 2017/745)
	Authorised representative in the European Community
	AC Power

2.2 Symbols on the Product

	Start / Stop Button
	Maximum water level
	Minimum water level
	Air Outlet

	Air Inlet
	Humidifier
	Unlocking direction of the connector between the air outlet and tube
	Hot Surface

2.3 Symbols on the User Interface

	Home
	Ramp
	Breathe wet
	My settings
	Report
	Wi-Fi
	Bluetooth
	Professional settings
	System settings
	Stop ventilation after activating the humidification function and dry the air pathway.
	FOT(Forced Oscillation Technique)
	Entered professional settings

2.4 Symbols on the Manual

WARNING!	Indicates the possibility of injury to the user or operator.
CAUTION!	Indicates the possibility of damage to the device.
IMPORTANT TIP!	Places emphasis on an operating characteristic.

3. Warnings, Cautions and Important Tips

WARNINGS!

- This device is intended for adult use only.
- This device is not intended for life support.
- The instructions in this manual are not intended to supersede established medical protocols.
- To ensure that you receive the safe, effective therapy prescribed for you, use only Viatom accessories.
- Do not wear a mask when the device is not turned on and is not functioning properly, as there is risk of suffocation.
- Do not use this device if there is a mixture of flammable anesthetics and air or oxygen or nitrous oxide around.
- Do not use this device in an environment with flammable gas and oxygen-rich environment. The device should be at least 1m away from the oxygen source during operation.
- Do not use the device near the source of toxic gas or harmful gas.
- Do not use this device in a temperature exceeding the specified temperature range.
- Do not place this device directly on carpets, fabrics or other flammable materials
- Do not place the device near curtains as this may impede the flow of cooling air, which may contribute to overheating.
- Do not use this device when the room temperature exceeds 35°C (95°F). When the room temperature exceeds 35°C (95°F), the air temperature in the tube may exceed 43°C (109°F). Thereby causing irritation or injury to the respiratory tract.
- Stability of the air temperature in the tube does not exceed $\pm 2^{\circ}\text{C}$ during the stable operation of the product.

- When using this device in a home environment, please place this device away from pets and children.
- Before use, please confirm that the tube is properly connected and avoid the risk of neck entanglement due to the use of breathing tube and hoses. Check the tube for damage or wear, and replace it if necessary.
- Incorrect use of masks or accessories may cause an increase in CO₂ concentration to a critical value or allow unconscious breathing, which may lead to breathing suffocation.
- Do not block the exhaust port of the mask. If you are using a full-face mask (the mask covers your mouth and nose), the mask must be equipped with a safety (entrainment) valve.
- Repairs, services and maintenance should only be carried out by the manufacturer or technicians expressly authorized by the manufacturer. Unauthorized servicing of the machine may result in personal injury, invalidation of the warranty or damage to valuable parts.
- If apnea continues to occur after using this device, please consult a physician.
- Please follow the doctor's advice and consider changing the treatment pressure. For the device to be more effective, please re-evaluate the treatment settings on a regular basis.
- Do not use the device or accessories in environments where electromagnetic equipment is present, such as CT scanners, Diathermy, RFID and electromagnetic security systems (metal detectors) as it may cause unacceptable risk to the patient or damage to the device. Some electromagnetic sources may not be obvious, if you notice any unexplained changes in the performance of this device, if it makes unusual or harsh sounds, disconnect the power cord and discontinue use. Contact your physician or qualified medical personnel immediately.
- You may experience drying of the nose, mouth or throat, bloating, ear or sinus discomfort, eye irritation, mask-related skin irritations and chest discomfort during the course of therapy with the device.
- You should report unusual chest pain, severe headache or increased breathlessness to your physician. An acute upper respiratory tract infection may require temporary discontinuation of treatment.
- If you feel uncomfortable when using the device, please stop using the device and contact your physician immediately, since the device may cause allergies.

- Humidification can increase the resistance of breathing system filters and the operator must monitor the breathing system filter frequently for increased resistance and blockage to ensure the delivery of the therapeutic pressure.
- Any serious incident that has occurred in relation to the device should be reported to the manufacturer and the competent authority of the Member State in which the user and/or patient is established.

CAUTIONS!

- U.S. federal law restricts this device to sale by or on the order of a physician.
- The patient is the intended operator.
- The device is intended for use by operators trained or experienced in similar equipment.
- Cleaning can be performed by the patient.
- The device must not be exposed to defibrillation, electrosurgery, X-ray (γ-ray) or infrared radiation. When the electromagnetic field includes magnetic resonance (MRI) or CT inspection environment and radio interference environment, the device will not function properly in such environment.
- It is necessary to check the air filter regularly to ensure that it is completely clean. A dirty air filter may raise the operating temperature and affect the performance of the device. Do not use wet air filter, and ensure that there is sufficient drying time.
- Before cleaning the device, disconnect the power to avoid electric shock. Do not immerse the device in water or other liquids. Please pay attention to waterproofing.
- When the accidental damage of the physical media causes system failure, power failure, hardware failure, and software failure, the protection of the physical environment should be enhanced, and the use of device should be strengthened.
- When man-made threats cause accidental loss of backup data, network management policies should be carefully improved; effective management of network keys should be enhanced, and misoperations should be prevented.
- When the user's personal information is inadvertently disclosed, the user's identification and authentication mechanism should be adopted, and the password should be long enough; it should be changed frequently, and the password should be kept in a confidential place; at the same time, the security awareness of personnel should be strengthened, the scope of dissemination of confidential information should be controlled, information transmitted in the network should be encrypted, etc.

- Do not use accessories or parts that are not recommended or configured. Incompatible accessories or accessories can result in degraded performance or affect the EMC performance of the device.
- Condensation may cause damage to the device. If the device is exposed to extremely hot or cold temperatures, the device should be adjusted to room temperature (operating temperature) before starting treatment. Do not use the device in a temperature environment outside the operating temperature range indicated in the parameters.
- Do not use this device under direct sunlight or near heating device, as these conditions will increase the temperature of the output airflow of the device.
- If the environment or power supply exceeds the specification range, it may cause an automatic shutdown or ventilation control that cannot meet the specifications.
- Please check if there is water in the device before use. The maximum water level limit of the water tank is 260ml.
- The patient is the intended operator. The patient has safe access the treatment function of the device. Components of the device cannot be maintained or repaired while the patient is using it.
- No modification to the device is allowed.
- Other equipment connected to the signal port of the product must meet the requirements of relevant standards, such as IEC 60601- 1 or IEC 62368- 1, etc.
- Do not place the device where it is difficult to disconnect the power supply.
- Although the device has passed ISO10993 and ISO 18562 tests, the easily accessible materials of the device may cause allergic reactions.
- If the machine is working abnormally, such as unusual noise, falling, water entering the machine, or broken machine shell, please disconnect the power supply, stop using the machine, and contact the device provider immediately.

IMPORTANT TIPS!

- Before use, make sure that the power cord is firmly installed to your treatment device.
- Please read and understand the entire user manual before operating this system. If you have any questions concerning the use of this system, contact your physician or healthcare professional.
- If you want to dispose of this device, please follow local environmental regulations.

- When you need to measure blood oxygen and ECG, please refer to the user manual of the appropriate oximeter and ECG.
- The correct wearing and position of the mask on the face is essential for the consistent operation of the device.
- When using, it must be ensured that the air filter is in good condition and installed in place.
- When the gas flow rate and setting exceed the recommended operating range, the output of the humidification system may be insufficient, and the relative humidity of the output gas may fall below 70%.
- To be able to use the humidifier safely, the humidifier must be placed below the breathing circuit between the mask and the air outlet of the device.
- Please regularly check whether the power supply and various pipelines are in order. If there are any problems, please stop using the device and replace related accessories.

4. Intended Use / Intended Purpose

The device provides positive pressure therapy for the treatment of adult obstructive sleep apnea syndrome in self-breathing patients weighing over 30kg (66lbs). This product can be used in the home as well as in clinical/hospital environments. It needs to be used under the guidance of a professional doctor.

5. Clinical benefits

The Non-invasive Ventilator should maintain the preset pressure continuously outputs to providing appropriate positive airway pressure during sleep of patient and propping open the airway to ensure that the breathing flow is smooth, to achieve the purpose of eliminating apnea events.

6. Contraindications

This device is not intended for patients who are dependent on mechanical ventilation, for example, those with central sleep apnea.

Studies have shown that the following pre-existing conditions may contraindicate the use of positive airway pressure therapy for some patients:

Absolute Contraindications: Pneumothorax, mediastinal emphysema; cerebrospinal fluid leak, traumatic brain injury, or pneumocephalus; shock caused by a variety of conditions before

treatment; active epistaxis; upper gastrointestinal bleeding before treatment; coma or impaired consciousness making the use of mask during therapy impossible; giant vocal fold polyp, etc.

Relative Contraindications: Severe coronary heart disease complicated with left ventricular failure, acute otitis media, excessive respiratory secretions and weak cough, weak spontaneous breathing, nasal or oral tracheal intubation and tracheotomy, severe nasal congestion caused by a variety of conditions, lung bullae, and allergies to breathing masks, etc.

IMPORTANT TIPS!

- An irregular sleep schedule, alcohol consumption, obesity, sleeping pills, or sedatives may aggravate your symptoms.
- Please use a legally marketed mask which meets ISO 17510: 2015. Refer to *8.4 Package Contents* for the mask recommended by Viatom.

CAUTION!

- Contact your healthcare professional if symptoms of sleep apnea recur. Contact your health care professional if you have any therapy-related questions.

7. Specifications

Items		Description
Physical	Dimensions (L x W x H)	270*168*91mm
	Weight	1.6kg
Operating environment	Temperature	5°C ~ 35 °C
	Relative humidity	10% ~ 95% (non-condensing)
	Atmospheric Pressure	70kPa ~ 106kPa
Storage environment	Temperature	-25°C ~ 60°C
	Relative humidity	10% ~ 95% (non-condensing)
	Atmospheric Pressure	70kPa ~ 106kPa
Operation noise	A-weighted sound pressure level	≤30 dB(A)
	A-weighted sound power level	≤38 dB(A)
Electro-magnetic compatibility	RF emissions	Group I, Class B
Electrical specifications	AC input	100 -240 V ~ 50/60Hz 2.2A Max
	DC output	3.75A, 90W
Safety features	Type of Protection Against Electric Shock	Class II Equipment
	Degree of Protection Against Electric Shock	Type BF Applied Part
	Mode of Operation	Continuous operation
	Degree of Protection Against Ingress of Water	IP22
	Safety level for flammable anesthesia gas	Cannot be used in the presence of flammable anesthesia gases mixed with air, oxygen or nitrous oxide.
	Installation and use classification	Portable Equipment

Items		Description
	Power Connection	Adapter with detachable power cord
Ramp	Time range	Off-60min
Pressure	Range	Mode (CPAP, APAP): 4-20 cmH ₂ O Mode (S, T, S/T): 4-25 cmH ₂ O
	Maximum Limit Pressure	30 cmH ₂ O (30 hPa) for more than 6 sec or 40 cmH ₂ O (40 hPa) for more than 1 sec.
	Static Pressure Control Accuracy	±(0.5 +4%)cmH ₂ O
	Dynamic Pressure Control Accuracy	(±1+4%)cmH ₂ O
Flow (STPD)	Maximum Flow	4cmH ₂ O: ≥120 L/min 9cmH ₂ O: ≥120L/min 15cmH ₂ O: ≥120L/min 20cmH ₂ O: ≥120 L/min 25cmH ₂ O: ≥120 L/min
Tidal volume(STPD)	Measurement range	0-3000 mL: ±(20% of actual reading) Other ranges: not defined
	Control accuracy	±(20% of actual reading)
	Minute ventilation measurement range	Range: 0-60L/min Accuracy: for breaths with minute ventilation greater than 15 L/min, the relative indication value is 50 mL ±20% of the actual transmitted ventilation volume. Other ranges: Not defined.
Humidification system output	Humidification capacity	Not less than 10 mg/L
	The maximum amount of water that can be evaporated from a storage tank	260±5mL
	Measurement Result	Ue=25%, k=2, Level of confidence P= 95%
	Gas temperature at patient connection port	<43°C

Items		Description
Wireless		Supports Bluetooth 5.0 BLE
		Supports Wi-Fi connection Transmission frequency or band(MHz): 2412 ~ 2472 Modulation type: DSSS; OFDM Effective radiation power(dBm): 16.49 (IEEE 802.11b), 15.13 (IEEE 802.11g), 14.96 (IEEE 802.11n)
Uploaded data	Monitoring parameters	Pressure IPAP EPAP VT MV Leak RR Ti I:E Spont% SpO2 PR HR
	Therapy data	AHI AI HI OAI CAI UAI RERA
	Usage data	Usage days Days with ≥ 4 hours of use Average usage time Total usage time High leak time High leak time percentage

Items		Description
		Number of mask removals
Use life		Main unit: 5 years Please refer to the instructions for the mask and tube for details on their service life.
Shelf life		5 years
Manufacture date		See the label on the product

8. Glossary

Apnea

A condition marked by the cessation of spontaneous breathing.

APAP (AutoCPAP)

Adjust CPAP pressure automatically to improve patient comfort based on monitoring of sleep events, such as apnea, hypopnea etc.

BPAP

Bi-level Positive Airway Pressure.

BPAP-S

BPAP- Spontaneous. A bi-level mode which responds to the patient's own inhalation and exhalation to keep synchronized with the patient's res rate.

BPAP-T

BPAP- Timed. A bi-level mode which automatically controls the time of inhalation and exhalation according to the preset parameter.

BPAP-ST

BPAP- Spontaneous/Timed. A bi-level mode that automatically switch work mode depending on the respiratory conditions of the patient.

CPAP

Continuous Positive Airway Pressure.

EPAP

Expiratory Positive Airway Pressure.

IPAP

Inspiratory Positive Airway Pressure.

LPM

Liters Per Minute.

OSA

Obstructive Sleep Apnea.

Ramp

A feature that may improve patient comfort during the therapy. It can reduce pressure and then gradually increase the pressure to the prescription setting so the patient can fall asleep more comfortably.

Rise Time

The time it takes for the device to change from EPAP to IPAP.

Res Rate

Respiratory Rate. Number of breaths per minute.

Resflex

A therapy feature that is enabled by your physician to provide pressure relief during exhalation.

Standby State

The state of the device when power is applied but the airflow is turned off.

min

Means the time unit "minute".

h

Means the time unit "hour".

yy mm dd / mm dd yy / dd mm yy

Denotes date.

9. Product Introduction

9.1 Model and available therapies

Model: LeRes-B, R100, LeRes-S, R200, LeRes-C, R10, LeRes-A, R20

Models are classified by different configurations, as detailed in the following table

		LeRes-B	R100	LeRes-S	R200	LeRes-C	R10	LeRes-A	R20
Appearance		Black	Black +Blue	Black	Black +Blue	White	White +Blue	White	White +Blue
Function	CPAP mode	●	●	●	●	●	●	●	●
	APAP mode	○	○	●	●	○	○	●	●
	S mode	●	●	●	●	×	×	×	×
	S/T mode	●	●	●	●	×	×	×	×
	T mode	●	●	●	●	×	×	×	×
	WIFI	○	○	○	○	○	○	○	○
	Bluetooth	○	○	○	○	○	○	○	○
	USB (Type-C)	●	●	●	●	●	●	●	●
Note: ● is for standard configuration, ○ is for optional configuration, and × is for unsupported configuration.									

Available therapies:

Terms	Description
CPAP mode	<p>Continuous positive airway pressure</p> <p>The device performs continuous positive pressure ventilation according to the preset treatment pressure, and maintains the treatment pressure throughout the breathing cycle.</p>
APAP mode	<p>Automatic continuous positive airway pressure mode APAP can be called Auto CPAP mode.</p> <p>During the ventilation, the treatment pressure is automatically increased when a respiratory event is detected, and reduced when the respiratory event disappears, that is, the pressure is automatically adjusted within the preset range by monitoring the respiratory event.</p>
S mode	<p>Autonomous trigger mode.</p> <p>When the device is ventilated, the patient's own breathing is used to control the operation of the device (the device provides inspiratory pressure when inhaling, and expiratory pressure when exhaling), and the breathing rate of the device is fully synchronized with that of the patient.</p>
S/T mode	<p>Autonomous trigger/time mode.</p> <p>When the device is ventilated, the device is fully synchronized with the patient's respiratory rate if the patient is breathing well spontaneously; if the patient's breathing is unstable or stops, the device will ventilate the patient according to the preset pressure and respiratory rate.</p>
T mode	<p>Time control mode.</p> <p>When the device ventilates, the patient is ventilated according to the preset pressure, respiratory rate and other parameters. This mode is mainly for patients with weak breathing trigger ability.</p> <p>Note: The most adverse breathing mode</p>

9.2 Components

The product consists of the main unit, power adapter and humidifier.

9.3 Overview

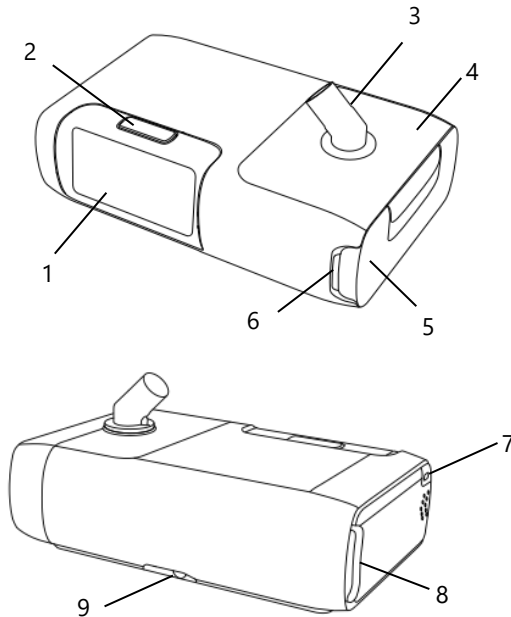

No.	Name	Function
1	Display Screen	Display menus for operation, messages, monitoring data, etc. Support touch screen operation.
2	Start / Stop Button	Start / Stop delivering air
3	Air Outlet	Deliver pressurized air; connect to the tube
4	Water chamber cover	Open the cover to extract the water chamber.
5	Water chamber	Store the water needed for the humidifier.
6	Indicator light	Indicator light.
7	USB interface	Export data or upgrade the device software
8	Air Inlet	Cover and secure the air filter, which is used to filter dust and pollen in the air entering the device.

9	DC Inlet	An inlet for the DC power supply.
---	----------	-----------------------------------

9.4 Package Contents

After unpacking the system, make sure you have everything shown here:

No.	Articles	Qty.
1	Device (Humidifier included)	1
2	Power Adapter	1
3	Air filter	1
4	Carrying case	1
5	Accompanying Documents	1

The product is not made with natural rubber latex.

Recommended devices and accessories:

Name	Model	Manufacturer	Remark
Pulse Oximeter (Optional)	PO6	Shenzhen Viatom Technology Co., Ltd.	CE 0197 HD 60137356 0001
Single-lead ECG recorder (Optional)	ER1-LW	Shenzhen Viatom Technology Co., Ltd.	CE 0197 HZ 2120274-1
Ventilation mask	11345	HSINER CO., LTD.	CE 2460, C548598 Basic UDI-DI: 47126880500007258NIVSZ
Breathing tube	70243	HSINER CO., LTD.	CE 2460, C548598 Basic UDI-DI: 47126880500007258NIVSZ
USB flash drive	8G	Customized	Customized

The product's service life is five years if the use, maintenance, cleaning is in strict accordance with the User Manual.

Note: When used with the Dynamic ECG recorder and Pulse Oximeter, the Non-invasive Ventilator is only an interface to display its value received, and does not involve any measurement, data processing and parameter algorithm.

WARNINGS!

- This device should only be used with the mask and accessories manufactured or recommended by Viatom or your prescribing physician. The use of inappropriate masks and accessories may affect the performance of the device and impair the effectiveness of the therapy.
- The use of the accessories other than those specified, with the exception of cables sold by the manufacturer of the equipment or system as replacement parts for internal components, may result in increased emissions or decreased immunity of the equipment or system.
- Do not pile up the long tube at the head of the bed, as it may be a strangulation hazard.
- Do not connect any equipment to the device unless recommended by Viatom or your physician.

IMPORTANT TIPS!

- If any of the above parts are missing, contact your physician.
- Contact your physician for additional information on the available accessories of this device. When using optional accessories, always follow the instructions enclosed with the accessories.

9.5 Working Principle

The product consists of an air compressor, control circuit, sensor, and humidifier. It continuously outputs a certain level of positive pressure and flow of air according to a preset pattern and applies it to the patient's airway through the tube and mask.

10. First Time Setup

10.1 Placing the Device

Place the device on a firm, flat surface.

WARNINGS!

- If the device has been dropped or mishandled, if the enclosure is broken, or if water has entered the enclosure, disconnect the power cord and discontinue use. Contact your physician immediately.

- If the room temperature is above 95°F (35°C), the airflow generated by the device may exceed 109.4°F (43°C). The room temperature must be kept below 95°F (35°C) while the patient uses the device.

CAUTIONS!

- Always ensure that the device is placed in an area where the screen and indicators are clearly visible.
- If the device has been exposed to either very hot or very cold temperatures, allow it to adjust to room temperature (approximately 2 hours) before starting setup.
- Make sure the device is away from any heating or cooling equipment (e.g., forced air vents, radiators, air conditioners).
- The device is not suitable for use in high humidity environments. Please ensure that no water enters the device.
- Make sure that no bedding, curtains, or other items are blocking the filter or vents of the device.
- Keep pets, pests or children away from the device to avoid small objects being inhaled or swallowed.
- To avoid explosion, this device must not be used in the presence of flammable gases (e.g., anesthetics).
- Tobacco smoke can cause tar build-up within the device, leading to device failure.
- Air must flow freely around the device for it to work properly.
- Make sure the power cord is accessible when placing the device, since the only way to shut down the device is to disconnect the power cord.

10.2 Installing and Replacing the Air Filter

The device is equipped with reusable **air filter** at the air inlet. Please check the air filter every 6 months, and replace the filter if you find any foreign matter or dust blocking the air inlet.

Follow the steps below to install or replace the air filter:

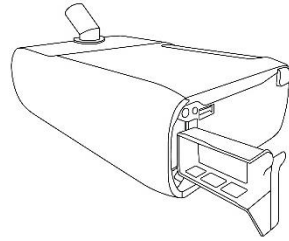
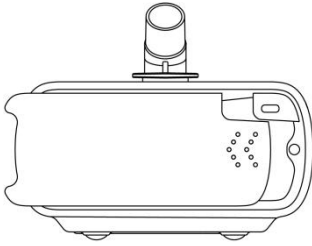

1. Push the side panel open in the direction indicated by the arrow to access the air inlet.
2. Put in the air filter in the right direction.
3. Insert the new filter assembly back into the side of the device, and close the side panel by swinging the door shut.

If you need to replace the air filter, simply remove the old filter and insert a new one in its place.

⚠️ WARNINGS!

Do not block the air inlet.

CAUTIONS!

- After receiving the equipment, please confirm whether the air filter has been installed in the air inlet. Please install it yourself if it is not pre-installed.
- The air filter must be in place when the device is operating. However, do not operate the device with a dirty air filter, as it may hinder proper functioning or even damage the device.
- Device must be unplugged when installing the air filter.
- The air filter must be installed correctly.
- The air filter should not be exposed to humid environments, temperatures below freezing, or direct sunlight.
- The air filter should be replaced every 6 months (or more frequently depending on the actual sanitary conditions).

10.3 Using the Humidifier

You can comfortably use the device by turning on the humidifier to increase the humidity of the inhaled air and prevent the mucous membrane of the nasal cavity from drying out. If you need to enable the humidification function, you need to fill in the water chamber for its well function. Please follow the steps below.

1. Open the cap and remove it from the humidifier.

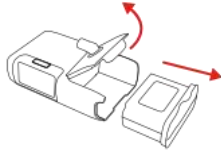

2. Fill it with water in an amount that does not exceed the maximum water level line.

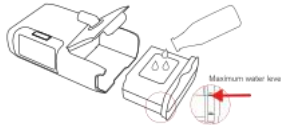

3. Put the water chamber back into the humidifier and close the cap.

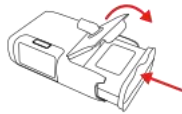

WARNINGS!

For safety reasons the device must be placed on a flat surface at a level lower than the head of the patient in bed, so that the condensate flows back into the chamber instead of remaining in the tube causing rainout.

CAUTIONS!

- Add no water or turn off the humidification function when the air humidity is already high.
- Only distilled or purified water should be filled. Adding other substances will have adverse effects.
- Make sure that the water does not exceed the maximum water level line.
- Do not tilt the water chamber when the water reaches the maximum water level.
- Empty the remaining water when the equipment is not in use.
- The humidifier is integrated with the main unit and cannot be easily replaced.
- Humidification level 1: It is recommended that the interval of adding water is 12h
Humidification level 2: It is recommended that the interval of adding water is 10h
Humidification level 3: It is recommended that the interval of adding water is 8h
Humidification level 4: It is recommended that the interval of adding water is 6h

Humidification level 5: It is recommended that the interval of adding water is 4h

Automatic level: It is recommended that the interval of adding water is 8h

10.4 Assembling the tube and Mask

- (1) Connect one end of the air tube firmly onto the air outlet of the device.



- (2) Connect the other end of the tube to the mask.



- (3) Wear the mask and adjust the headband to ensure it fits with the face without air leakage.



CAUTIONS!

- Do not pull the tube to avoid air leakage.
- If the mask and tube are damaged, stop using them and replace them promptly.
- Please use a legally marketed ventilation mask (standard 22mm connector diameter) and breathing tube (22mm connector diameter and $1.8 \pm 10\%$ tube length), as recommended in Chapter 8.

WARNINGS!

- Pressures must be verified by your physician when alternate or optional accessories are in place.
- If you are using a full-face mask (a mask covering both your mouth and nose), make sure the mask is equipped with a safety (entrainment) valve.
- The patient should observe the following instructions to minimize the risk of CO₂ rebreathing:

- Use only the provided or recommended tube and mask.
- Do not wear the mask for more than a few minutes while the device is not operating.
- Use only masks with vent holes. Do not block or try to seal the vent holes in the exhalation port.
- To prevent disconnection of the tube or tube system during use, only tubes in conformance with ISO 5367 or ISO 80601-2-74 should be used.

10.5 Connecting to Power

- (1) Insert the plug of the power adapter into the DC Inlet on the back of the device

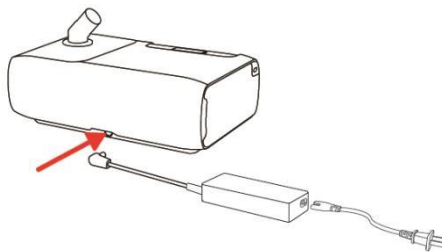

- (2) Connect the power cord to the power adapter
- (3) Plug the other end of the power cord into the power outlet.

⚠️ WARNINGS!

- Connect to appropriate power for proper operation of the device.
- If the power is disconnected during operation, a beep sound will occur. Please stop using the device and check the power connection.
- Do not connect the power supply when the device is damaged.
- If the surface of the power adapter or power cord is damaged, stop using the device and replace the adapter or power cord.

10.6 Operation Guide

The user interface of this device, with a display touch screen and buttons, allows you to adjust the device settings and check your treatment information. You can adjust the settings through the touch screen.

- ⏻ – short press to start delivering air, press and hold for 5 seconds to stop.

 - select to quickly access the Ramp feature setting page.



- select to quickly access the Home page.

WARNINGS!

- Be sure to follow your physician's instructions on adjusting the settings! To order any accessories not included with this device, contact your equipment supplier.
- DO NOT connect any ancillary equipment to this device unless recommended by Viatom or your physician. If you experience chest discomfort, shortness of breath, stomach bloating, or severe headache when using the device, contact your physician or qualified medical personnel immediately.

11. Routine Use

11.1 Power on/off

Power on: The device will automatically power on after connecting to the power supply, and enter the standby mode after a few seconds.

Power off: The device will automatically shut down when it is disconnected from the power supply in the non-ventilated state. Otherwise, the shutdown will trigger the power-down prompt.

CAUTION!

- Before each use, examine the tube for damage or debris. If necessary, clean the tube to remove debris. Replace any damaged tube. Make sure that the mask does not leak.

11.2 Adjusting the tube

Lie down on your bed, and adjust the tube so it is free to move if you turn during sleep. Adjust the mask and headgear until you have a comfortable fit and no airflow leaks around the mask.

CAUTION!

- Make sure that the mask and tube are properly installed without any blockage or leakage.

11.3 Turning on the Airflow

Turning on: After adjusting the tube and mask, press the "Start/Stop" button, the device will start delivering air while the screen showing the treatment pressure and other parameters.

Turning off: press the "Start/Stop" button to stop the airflow.

CAUTION!

- If the power supply is restored within 60 minutes, the device will automatically return to the state before the power failure when the power supply is interrupted (e.g., power failure).
- Under normal condition: There is a vent hole on the top of the full mask, when the patient exhales, the exhaled carbon dioxide is squeezed out through the hole by the patient exhalation pressure and the device output pressure.
- In a single fault state: When the patient exhales during a power failure, the patient will expel carbon dioxide gas through the vent hole on the mask and tube, and when the patient inhales during a power failure, the patient will inhale fresh air through the vent hole on the mask and tube.

11.4 Humidify the air

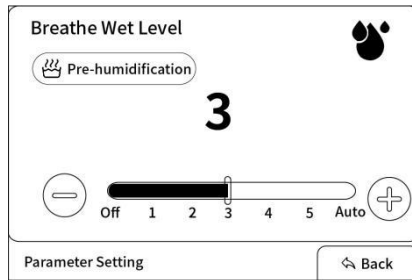

Pay attention to the description next to the icon  when using the humidifier. When the Breathe Wet feature is off, the device stops humidifying with no icon displayed; when it is set to auto mode, the device will automatically adjust the humidity level.

You can turn on the humidifier to moisturize the output air from the device. Select the [Breathe Wet] menu to adjust the humidity level. Then turn on the airflow, the humidification will be automatically activated.

CAUTION!

- Observe the water level of the water chamber before using the humidifier. Make sure there is sufficient water in the water chamber, avoid heating the device with an empty water chamber.

11.5 Using the Ramp Feature

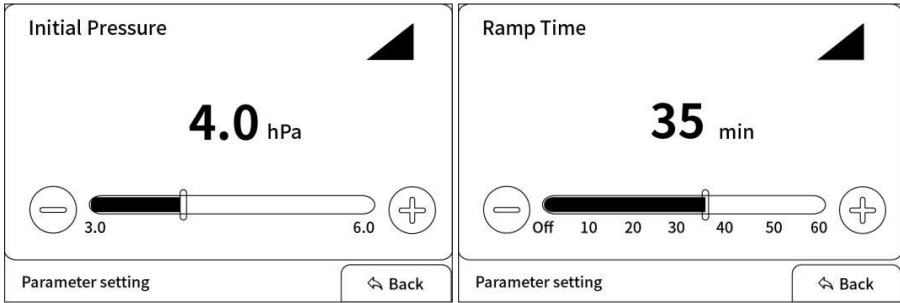

Every time the feature is enabled, the pressure will drop to the set initial pressure, and then gradually rise to the prescribed treatment pressure according to the preset ramp time, so as to ensure patient comfort. Select [Ramp] menus, adjust the [Initial pressure] and [Ramp time] to activate the feature.

CAUTIONS!

- You can use the ramp feature as often as you wish during sleep.
- The ramp feature is not prescribed for all users.

11.6 Viewing the report

When the device is in standby mode, you can view the using report in the menu, which presents the working time, average use time, etc. Select [Report], data of the day will be shown by default, you can select other time for query.

11.7 Professional Setting

Professional Setting is a password-required mode for clinical operation or settings under professional guidance.

Select [Professional Setting] in the menu, input the correct password to enter the professional menu, where you can enable/disable the professional mode and adjust the therapy mode and parameters.

Password: 0319

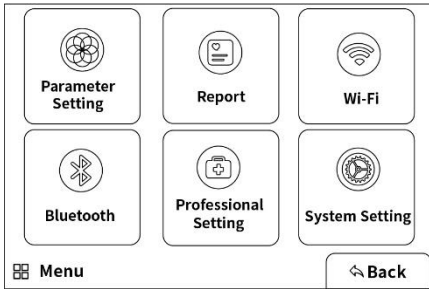

Menu

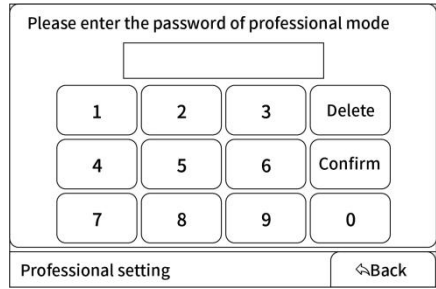

Entering password

Parameters vary according to different therapy modes (see more details in 10.8). You can drag the sliding bar or click "+" and "-" buttons to adjust the parameters.

11.8 Navigating the Menu

The system displays specified menu items for different users, including three modes: normal mode (default), professional mode, and maintenance mode. The device adopts normal mode by default.

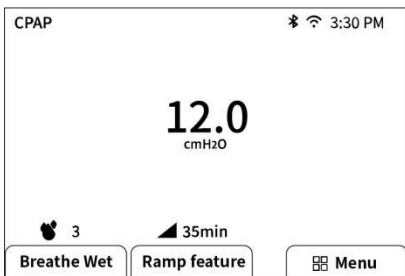

Standby interface

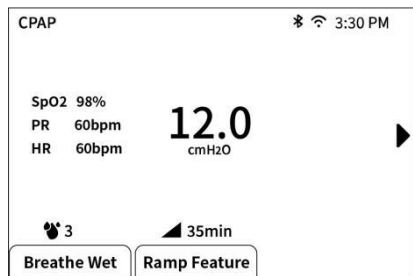

Working interface

1.0.8.1 Normal mode

This mode is for the patient to set up the device. It includes My Settings, System Settings, View Reports, etc. See the table below for detailed menu descriptions.

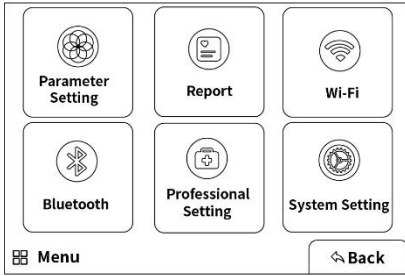

Menu

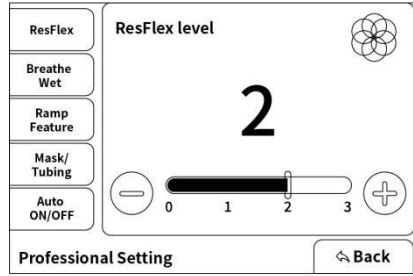

My settings

Menu		Description
My settings	Resflex	This feature enables the device to automatically reduce the treatment pressure when the patient exhales, so as to make the user more comfortable. 0 means this function is disabled. Available range: 0-3 Default: 2.
	Breathe Wet	Adjust the humidity level. As the numbers increase, the humidity rises accordingly. Available range: Off/1-5/Auto Default: Off
		Pre-humidification: When the function is on, the humidifier will start working 30 minutes before it is ventilated.
	Ramp	Initial pressure: adjust the starting pressure of the ramp feature. Available range: 3-20 cmH2O Default value: 4 cmH2O Note: The initial pressure must not exceed the treatment pressure.
		Ramp time: adjust the time during with the initial pressure rises to the prescribed treatment pressure. Available range: Off-60 min Default value: 15 min.
	Mask/tube	Mask type: full-face mask/nasal mask/nasal pillow mask. Default: Nasal mask.
Tube type: 15mm/22mm.		

Menu		Description
		Default: 22mm.
		Mask Fitting test: Test whether the mask is worn correctly. If the user fails the test, the mask should be readjusted.
	Auto on/off	Auto on: The device turns on the airflow itself when the user puts on the mask and starts breathing. Available options: On/Off Default: On
		Auto off: The device turns off the airflow itself when the user removes the mask. Available options: On/Off Default: On
Report	My Info	This function provides summary statistics of your therapy, including use time, etc. The patient can check the information of certain days.
Wireless	Wi-Fi settings	Turn on/off Wi-Fi, connect to the desired network.
Bluetooth	Bluetooth settings	Turn on/off the Bluetooth, connect to the desired device.
System settings	Consumables Reminder	This function is used for setting the use time of tube, Water chamber and mask. This is for replacement reminders. Available options: Off/1-12 months. Default: Off
		This function is used for setting the use time of filter. This is for replacement reminders. Available options: Off/1-6 months. Default: Off
	Pressure unit	Adjust the pressure unit. Available options: cmH2O/hPa Default: cmH2O.
	Brightness	Adjust the screen brightness. Available range: 5-100% Default: 60%.

Menu		Description
Automatic Screen sleep		The device will automatically return to the standby screen and go to sleep if no operation is detected in a preset period of time. Available options: Off/ 30s/ 60s/90s/120s Default: 30s
Language		Adjust the language of the system.
Date		Adjust the date of the system.
Date Format		Adjust the data format of the system. Available option: yy/mm/dd; mm/dd/yy; dd/mm/yy Default: yy/mm/dd.
Time		Adjust the time of the system.
Time Format		Adjust the time format of the system. Available options: 24h/12h Default: 24h.
Reminder		Adjust the reminder.
Volume		Adjust the reminder volume. Available range: 0-100% Default: 30%.
Delete data		Remove all the usage data, including ventilation data, report, etc.
About		View the device information, including model, software version, SN, etc.

10.8.2 Professional mode

This mode is for clinical operation or settings under professional guidance. To prevent patients from misuse, the user needs to enter the password to switch to the professional mode.

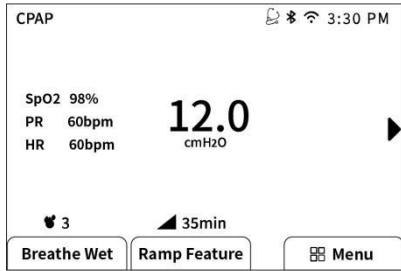

Working interface

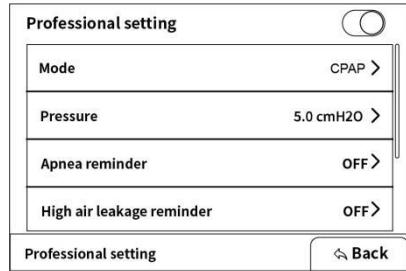

Parameters configuration

Menu		Description
Mode	Therapy mode	Adjust therapy mode. Available options: CPAP, APAP, S, S/T, T. Note: Different models vary in its therapy mode.
Parameter	Pressure	Adjust the therapy pressure in CPAP mode Available range: 4.0 - 20.0 cmH2O. Default: 6.0 cmH2O.
	Maximum pressure	Adjust the maximum pressure in APAP mode Available range: 4.0 - 20.0 cmH2O Default: 12.0 cmH2O Note: the maximum pressure must be higher than the corresponding minimum pressure.
	Minimum pressure	Adjust the minimum pressure in APAP mode. Available range: 4.0 - 20.0 cmH2O, Default: 4.0 cmH2O
	Inhale pressure	Adjust the inhale pressure in S, S/T, T modes. Available range: 6.0 - 25.0 cmH2O Default: 10.0 cmH2O. Note: the inhale pressure must be higher than the corresponding exhale pressure.
	Exhale pressure	Adjust the exhale pressure in S, S/T, T modes. Available range: 4.0 - 25.0 cmH2O Default: 6.0 cmH2O.
	Inhale time	Adjust the inhale time in S, S/T, T modes.

Menu		Description
		Available range: 0.3 - 4.0s Default: 1.0s
	Res rate	Adjust the respiratory rate in S, S/T, T modes. Available range: 5 - 30 bpm Default: 12 bpm
	Rise time	Adjust the rise time in S, S/T, T modes. Available range: 100- - 900 ms Default: 200 ms
	Inhale trigger sensitivity	Adjust the trigger sensitivity of inhalation in S, S/T, T modes. Available range: Auto/1-5 level Default: 3
	Exhale trigger sensitivity	Adjust the trigger sensitivity of exhalation in S, S/T, T modes. Available range: Auto/1-5 level Default: 3

10.8.3 Maintenance mode

This mode is **used** to upgrade software or restore the factory setting. Switching to maintenance mode requires manual password input. To prevent patients from misuse, the service personnel needs to enter the password to switch to the maintenance mode.

Menu	Description
Software upgrade	Upgrade the software.
Reset the device	Reset the device to factory settings.
Calibration	Calibrate the pressure and flow the device.
Delete local data	Delete data stored on the device, including ventilation data, ventilation configuration records, device statistics (turbo time, running time, ventilation time), logs, etc., i.e., reverts to the factory storage state.
Diagnose	Debugging the device components to obtain their status for fault diagnosis, supported components include turbines, heating plates and heating lines.

11.9 Device Messages

The system displays prompt messages on the screen according to the current state. See the table below for more details.

Message	Description
High leakage	Indicates improper connection of the mask or tube when the airflow is on.
Patient apnea	Indicates an apnea occurred during the therapy and lasted longer than the preset duration.
Tube disconnected	Indicates a disconnection among the air outlet, tube and mask when the airflow is on.
Tube blocked	Indicates a blockage in the tube or air inlet during the operation.
Check power	Indicates an incompatible power supply is attached, or power cord is not fully inserted into device's power inlet. Please use the supplied power adapter.
Please change tube	When the Consumables Reminder is enabled, the message will be displayed if the preset replacement time reached but without replacing the tube.
Please change water chamber	When the Consumables Reminder is enabled, the message will be displayed if the preset replacement time reached but without replacing the water chamber.
Please change filter	When the Consumables Reminder is enabled, the message will be displayed if the preset replacement time reached but without replacing the filter.
Please change Mask	When the Consumables Reminder is enabled, the message will be displayed if the preset replacement time reached but without replacing the mask.
Heating humidification malfunction (202)	Restart the device and check if the water tank temperature has risen. If the issue persists, please contact after-sales service for assistance.
Low output pressure (316)	During use, the air inlet may be blocked; water may have entered the device due to high water levels or movement; dust may have accumulated on the filter cotton; or contact after-sales service for assistance.
Please clear the storage space	The storage space is below 10%, replace or clear the memory card.

11.10 Pairing with Pulse Oximeter

The device can be used together with a pulse oximeter with the screen displaying the its measurements. Follow the steps below to pair with the pulse oximeter.

1. Wear the pulse oximeter and keep its working condition.
2. Select the [Bluetooth] in the device's menu, turn on the Bluetooth function, and wait for the device to search for the pulse oximeter.
3. Select the searched pulse oximeter and wait for their connection. Now you can see the measurement parameters of the pulse oximeter on the device screen.

CAUTIONS!

The device only supports connection to pulse oximeters in the accessory list, please refer to Chapter 8 for specific models.

11.11 Pairing with ECG Recorder

The device can be used together with the ECG recorder with the screen displaying its measurements. Follow the steps below to pair the ECG recorder.

1. Wear the ECG recorder and keep its working condition.
2. Select the [Bluetooth] in the device's menu, turn on the Bluetooth function, and wait for the device to search for the ECG recorder.
3. Select the searched ECG recorder and wait for their connection. Now you can see the measurement parameters of the ECG recorder on the device screen.

CAUTIONS!

The device only supports connection to the ECG recorder in the accessory list, please refer to Chapter 8 for specific models.

12. Using Wi-Fi, Bluetooth and Type-C

12.1 Connecting to Wi-Fi Network

- 1) Select [Menu]-[Wi-Fi] to access the “Wi-Fi” setup interface.
- 2) The interface displays an on/off button and a certain number of available Wi-Fi networks. Turn on the Wi-Fi, and wait for the searching of your desired Wi-Fi network.
- 3) Select the desired network, enter the password and confirm.
- 4) Wait 0-15 seconds for the connection result.

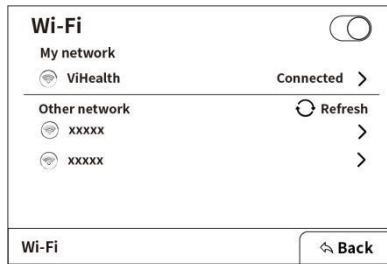

12.2 Using the Bluetooth

- 1) Select [Menu]-[Bluetooth] to access the “Bluetooth” setup interface.
- 2) The interface displays an on/off button and a certain number of available devices of specific models as recommended in Chapter 8. Turn on the Bluetooth, and wait for it to search for the desired device.
- 3) Select the desired device, and wait for the connection result.

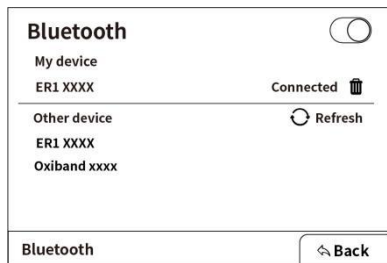

12.3 Using Type-C

Data transmission

- 1) Insert a specified USB flash drive to the Type-C interface.
- 2) The device identifies if it is a data export USB flash drive.
- 3) Select [Yes] to proceed with data export.

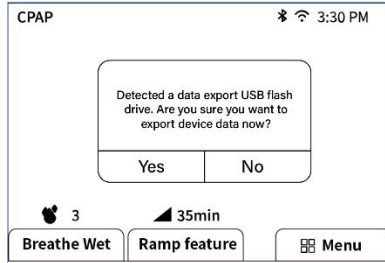

Software upgrading

- 1) Insert a specified USB flash drive to the Type-C interface.
- 2) The device identifies if it is an upgrade USB flash drive.
- 3) Select [Yes] to upgrade device software.

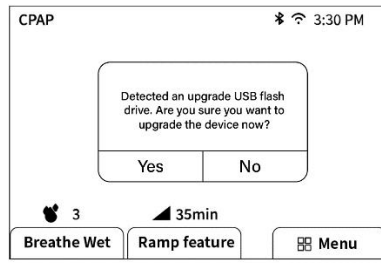

12.4 Cybersecurity

- 1) Operating environment.

Hardware configuration: Bluetooth module, Wi-Fi module, TYPE-C interface.

Software environment: support for Bluetooth BLE protocol 5.0, Wi-Fi protocol, and TYPE-C driver.

Network conditions: support for Bluetooth, Wi-Fi, and TYPE-C transmission.

- 2) Security software.

None.

3) Data and device interfaces.

Bluetooth communication interface, Wi-Fi communication interface, and TYPE-C interface.

4) User access control.

Bluetooth and Wi-Fi communication with a private protocol and authentication control.

5) Software environment and security software update requirements.

Any update requirements of the software environment will be presented in the updated user manual or software.

CAUTIONS!

- Viatom only provides the function without getting involved in the data processing.

13. Cleaning

WARNINGS!

- Regular cleaning of the device and its accessories is very important for the prevention of respiratory infections.
- To avoid electric shock, always unplug the device before cleaning.
- Follow the manufacturer's instructions on cleaning the mask and tube and on determining the frequency of cleaning.
- Before cleaning, check whether the device has been disconnected from the power supply, whether the power cord has been unplugged, and whether the water chamber of the device has cooled down. Make sure the plate has cooled down to room temperature, to avoid the risk of burns.
- Do not open or modify the device. There are no user serviceable parts inside. Repairs and servicing should only be performed by an authorized service agent.

CAUTIONS!

- Overheating of the materials could lead to early fatigue of these materials.
- Do not use solutions containing chlorinated lime, chlorine, or aromatic to clean the device and its accessories. Liquid soap containing moisturizing agents or antimicrobials should not be used either. These solutions may harden cleaned materials or reduce their lifespan.
- Do not clean or dry the device and its accessories when the temperature is higher than 80°C (176°F). High temperatures could reduce product life.

- Do not immerse the device in any fluids.
- If the device is transferred to another patient, components in close contact with the previous owner, including the mask, headgear, tube, air filter, and water chamber should be cleaned, disinfected or replaced to prevent cross-infection.
- If the product or its accessories are determined not to be visually clean at the end of the cleaning step, either repeat the relevant cleaning steps specified below or safely dispose of the product or its accessories.
- The product and its accessories shall conform with ISO 17664:2017.

13.1 Cleaning the Device

- 1) Wipe the surface of the device with a soft, slightly damp cloth dampened with 75% alcohol.
- 2) Adjust the rotating connector between the air outlet and breathing tube until the little triangle mark is aligned with the symbol , then pull out the connector to clean its inner surface and the air outlet.

CAUTIONS!

- The device should only be used after the enclosure is dry, so that no moisture enters the device.
- It is recommended to clean the enclosure once a month.

13.2 Cleaning the Mask and Tube

For details, refer to the cleaning instructions in the user manual of the mask and tube or consult customer service personnel.

13.3 Cleaning the Water Chamber

Clean the water chamber with a soft cloth (dip the soft cloth in 75% alcohol. if necessary), rinse it thoroughly, and then wipe it dry with a soft cloth. Dry the water chamber and install it back in the device. It is recommended to change the water daily and thoroughly clean the water chamber once a week.

CAUTIONS!

- Emptying and cleaning the water chamber will help prevent mold and bacteria growth.

- Inspect the water chamber for any leak or damage. Replace the water chamber if any damage is present.
- Clean the water chamber only after the water in it cools. Make sure that no water enters the device.

14. Maintenance

The device has a 2-year warranty and 5-year service life (Use life). No maintenance is needed during its service life if it is used in accordance with the user manual, but examination by the authorized dealer is recommended after 5 years' service.

No maintenance is needed for the humidifier if it is used in accordance with the user manual. If the device malfunctions, contact the authorized dealer immediately.

WARNINGS!

- If you notice any unexplained changes in the performance of the device, if it is making unusual or harsh sounds, if it has been dropped or mishandled, if the enclosure is broken, or if water has entered the enclosure, discontinue use. Contact your physician.
- Repairs and adjustments must be performed by Viatom-authorized service personnel only. Unauthorized service could cause injury, invalidate the warranty, or result in costly damage.
- If necessary, contact your local authorized dealer or Viatom for technical support and documents.

15. Storage and Disposal

15.1 Storage

- Turn off the device
- Disconnect the power supply.
- Clean the device and its parts and accessories.
- Store them in a dry place.

CAUTIONS!

The device should be stored in designated environment. See Chapter 6 Specifications.

15.2 Disposal



Electrical product components contain chemical substance which may pollute environment, when the device reaches the end of its service life, dispose of the device and packaging in accordance with local laws and regulations.

16. Troubleshooting

The table below lists common problems you may have with the device and possible solutions to those problems. If none of the corrective actions solve the problem, contact your physician.

16.1 Common problems in patients and corresponding solutions

Problem	Possible cause	Solution(s)
Leaking mask	The mask size or model may not be correct, or the mask is not positioned correctly.	Refer to the mask instruction for detailed information to confirm the correct mask size. Or use the mask-fit test function to check air leakage.
Dry, cold, runny, and blocked nose	The nose reacts to the airflow and cold. Due to airflow, the air becomes cold, leading to nasal mucosa irritation and subsequent dryness and swelling.	Increase the humidity setting of the device.
Water in mask	When the humidifier is used, the humidified air tends to condense in the cold tube and mask if the room temperature is low.	Turn the humidity setting down or raise the room temperature.
Dry mouth and throat	The patient sleeps with his or her mouth open, and the pressurized air goes out via the mouth, leading to nasal and throat dryness.	Increase the humidity setting of the device. Use a chin strap to prevent the mouth from opening during sleep or use a full-face mask.
The airflow pressure feels too high.	The Ramp feature is disabled.	Enable the Ramp feature.

16.2 Common problems in the device and corresponding solutions

Problem	Possible cause	Solution(s)
The device does not work when it is turned on	Power is not connected properly.	Ensure that the power cord, power adapter, and the device are connected properly.
	There is no voltage.	Check whether a power outage occurs by turning on a light or other means. If you cannot find any cause, contact your equipment supplier.
The airflow continues after it is turned off.	The device is air-drying the tube.	The airflow will stop in 30 minutes after the process is completed.
Abnormal screen display.	The device is dropped or struck.	Unplug and re-plug the power cord. If the problem still exists, contact your equipment provider.
The device is working, but the pressure inside the mask differs from the set treatment pressure	The tube is not connected properly, or there is air leakage.	Reconnect the tube properly. If the problem still exists, contact your equipment provider.
The device produces very low pressures	The air inlet of the device may be blocked.	Clean or replace the air filter.
	When the Ramp feature is enabled, it takes some time for the initial pressure to rise to the treatment pressure. This is normal.	If necessary, disable the Ramp feature, or set the ramp time shorter.
Water leakage in the water chamber	The water chamber is incorrectly installed.	Check whether the water chamber is correctly installed.
	The water chamber is broken.	Check whether there are visible damages. Contact customer service for a new water chamber.
No response from	Touch screen failure	Restart the device.

Problem	Possible cause	Solution(s)
the touching screen.		If the problem still exists, contact your equipment provider.
Unable to connect to the Oximeter.	The Bluetooth is off.	Turn on the Bluetooth of the device.
	The Oximeter is off.	Properly wear the Oximeter and keep it well-functioning.
Unable to connect to the ECG recorder.	The Bluetooth is off.	Turn on the Bluetooth of the device.
	The ECG recorder is off.	Properly wear the ECG recorder and keep it well-functioning.

17. Travelling with the Device

You can take the device with you wherever you go. Just keep the following in mind:

- Use the travel bag provided to prevent damage to the device.
- Empty the water chamber and pack it separately in the travel bag.
- If you are traveling to a country with a line voltage different than the one you are currently using, a different power cord or an international plug adaptor may be required to make your power cord compatible with the power outlets of the country to which you are traveling. Contact your device provider for additional information.

18. EMC Requirements

Guidance and manufacture's declaration-- electromagnetic emissions		
The device is intended for use in the electromagnetic environment specified below. The user of the device should ensure that it is used in such an environment.		
Emissions Test	Compliance	Electromagnetic Environment-- Guidance
RF emissions CISPR 11	Group 1	The device uses RF energy only for its internal function. Therefore its RF emissions are very low and are not likely to cause any interference in nearby electronic equipment
RF emissions CISPR 11	Class B	The device is suitable for use in all establishments including domestic establishments and those directly connected to the public low-voltage power supply network that supplies buildings used for domestic purposes.
Harmonic emissions IEC61000-3-2	Class A	

Guidance and manufacture's declaration-- electromagnetic immunity			
The device is intended for use in the electromagnetic environment specified below. The user of the device should make sure that it is used in such an environment.			
Immunity Test	IEC 60601 Test Level	Compliance Level	Electromagnetic Environment-- Guidance
Electrostatic discharge (ESD)	±8 kV contact, ±2 kV, ±4 kV, ±8	±8 kV contact, ±2 kV, ±4 kV, ±8	Floor should be wood, concrete or ceramic tile. If floors are

IEC 61000-4-2	kV, ± 15 kV air	kV, ± 15 kV air	covered with synthetic material, the relative humidity should be at least 30%.
Electrical fast transient / burst IEC 61000-4-4	± 2 kV for power supply lines	± 2 kV for power supply lines	Mains power quality should be that of a typical commercial or hospital environment.
Surge IEC 61000-4-5	± 1 kV line(s) to line(s)	± 1 kV line(s) to line(s)	Mains power quality should be that of a typical commercial or hospital environment.
Voltage dips, short interruptions and voltage variations on power supply input lines IEC 61000-4-11	0% UT; 0.5 cycle At 0°, 45°, 90°, 135°, 180°, 225°, 270° and 315° 0% UT; 1 cycle 70% UT; 25 / 30 cycle At 0° 0% UT; 250 / 300 cycle	0% UT; 0.5 cycle At 0°, 45°, 90°, 135°, 180°, 225°, 270° and 315° 0% UT; 1 cycle 70% UT; 25 / 30 cycle At 0° 0% UT; 250 / 300 cycle	Mains power quality should be that of a typical commercial or hospital environment. If the user of the device requires continued operation during power mains interruptions, it is recommended that the device be powered from an uninterruptible power supply or a battery.
Power frequency (50 /60 Hz) magnetic field IEC 61000-4-8	30 A/m	30 A/m	Power frequency magnetic fields should be at levels characteristic of a typical location in a typical commercial or hospital environment.
Note: U_r is the AC mains voltage prior to application of the test level.			

Guidance and manufacture's declaration-- electromagnetic immunity			
The device is intended for use in the electromagnetic environment specified below. The user of the device should make sure that it is used in such an environment.			
Immunity Test	IEC 60601 Test Level	Compliance Level	Electromagnetic Environment-- Guidance
Conducted RF IEC 61000-4-6	3 V 0.15 MHz ~	3 V 0.15 MHz ~	Portable and mobile RF communications equipment should be used no closer to any

<p>Radiated RF IEC 61000-4-3</p>	<p>80 MHz 6 V in ISM and amateur radio bands between 0.15 MHz and 80 MHz</p> <p>10 V/m 80 MHz to 2,7 GHz</p>	<p>80 MHz 6 V in ISM and amateur radio bands between 0.15 MHz and 80 MHz</p> <p>10 V/m 80 MHz to 2,7 GHz</p>	<p>part of the device, including cables, than the recommended separation distance calculated from the equation applicable to the frequency of the transmitter.</p> <p>Recommended separation distance</p> $d = 1.17 \sqrt{P}$ $d = 0.35 \sqrt{P} \text{ 80 MHz to 800 MHz}$ $d = 0.70 \sqrt{P} \text{ 800 MHz to 2.5 GHz}$ <p>Where P is the maximum output power rating of the transmitter in watts (W) according to the transmitter manufacturer and d is the recommended separation distance in meters (m).</p> <p>Field strengths from fixed RF transmitter, as determined by an electromagnetic site survey, a should be less than the compliance level in each frequency range.</p> <p>Interference may occur in the vicinity of equipment marked with the following symbol:</p> 
----------------------------------	--	--	--

Note 1: At 80 MHz and 800 MHz, the higher frequency range applied.

Note 2: These guidelines may not apply in all situations. Electromagnetic propagation is affected by absorption and reflection from structures, objects and people.

^a Field strengths from fixed transmitters, such as base stations for radio (cellular / cordless) telephones and land mobile radios, amateur radio, AM and FM radio broadcast and TV broadcast cannot be predicted theoretically with accuracy. To assess the electromagnetic environment due to fixed RF transmitters, an electromagnetic site survey should be considered. If the measured field strength in the location in which the device is used exceeds the applicable RF compliance level above, the device should be observed to verify normal operation. If abnormal performance is observed, additional measures may be necessary, such as re-orienting or relocating the device.

^b Over the frequency range 150 kHz to 80 MHz, the field strengths should be less than 10 V/m.

Recommended separation distances between portable and mobile RF communications

equipment and the device			
The device is intended for use in an electromagnetic environment in which radiated RF disturbances are controlled. The customer or the user of the device can help prevent electromagnetic interference by maintaining a minimum distance between portable and mobile RF communications equipment (transmitters) and the device as recommended below, according to the maximum output power of the communications equipment.			
Rated maximum output of transmitter W	150 kHz ~ 80 MHz $d = 1.17\sqrt{P}$	80 MHz ~ 800 MHz $d = 0.35\sqrt{P}$	800 MHz ~ 2.5 GHz $d = 0.70\sqrt{P}$
0.01	0.12	0.04	0.07
0.1	0.37	0.13	0.23
1	1.17	0.35	0.70
10	3.70	1.11	2.22
100	11.7	3.50	7.00
Note 1: At 80 MHz and 800 MHz, the higher frequency range applied.			
Note 2: These guidelines may not apply in all situations. Electromagnetic propagation is affected by absorption and reflection from structures, objects and people.			
For transmitters rated at a maximum output power not listed above, the recommended separation distance d in meters (m) can be estimated using the equation applicable to the frequency of the transmitter, where P is the maximum output power rating of the transmitter in watts (W) according to the transmitter manufacturer.			

⚠️ WARNINGS!

- This device should not be used in the vicinity or on the top of other electronic equipment such as cell phone, transceiver or radio control products. If you have to do so, the device should be observed to verify normal operation.
- The use of accessories and power cord other than those specified, with the exception of cables sold by the manufacturer of the equipment or system as replacement parts for internal components, may result in increased emissions or decreased immunity of the equipment or system.
- This device may be interfered with by other equipment, even if that other equipment complies with CISPR EMISSION requirements.

19. Limited Warranty

Shenzhen Viatom Technology Co., Ltd. warrants that the device shall be free from defects of workmanship and materials and will perform in accordance with the product specifications for a period of two (2) years for the main unit, and six (6) months for all accessories. Note that the air filter, mask and tube are not covered by the warranty.

If the product fails to perform in accordance with the product specifications, Viatom will repair or replace, at its option, the defective material or any of its component. Viatom will pay customary freight charges from Viatom to the dealer location only. This warranty does not cover:

- Any damage caused by accident, misuse, abuse, alteration and other defects not related to material or workmanship.
- Repairs carried out by any service organization that has not been expressly authorized by Viatom to perform such repairs;

VIATOM DISCLAIMS ALL LIABILITY FOR ECONOMIC LOSS, LOSS OF PROFITS, OVERHEAD OR CONSEQUENTIAL DAMAGES WHICH MAY BE CLAIMED TO ARISE FROM ANY SALE OR USE OF THIS PRODUCT. SOME STATES DO NOT ALLOW THE EXCLUSION OR LIMITATION OF INCIDENTAL OR CONSEQUENTIAL DAMAGES, SO THE ABOVE LIMITATION OR EXCLUSION MAY NOT APPLY TO YOU.

To exercise the rights under this warranty, contact the local authorized dealers or:

Shenzhen Viatom Technology Co., Ltd



901, Building West, Lepu Tower, No.66 Xingke Road, Xili Community, Xili Street,
Nanshan District, Shenzhen, 518055, Guangdong P.R. China

www.viatomtech.com



MedNet EC-REP GmbH

Borkstrasse 10 · 48163 Muenster · Germany

PN: IFU-256-000023-00

Version: V1.1

Date: October 2025

